

# NOVEL SPHERICAL NEAR-FIELD ANTENNA MEASUREMENT TECHNIQUES ADVANCE STATE-OF-THE ART

A. Ray Howland, P.E.; Carl W. Sirles; Michael H. Sewell

## *ATDS-HOWLAND*

4540 Atwater Court; Suite 107  
Buford GA USA 30518

### ABSTRACT

Widespread deployment of cellular phones and use of wireless devices such as personal digital assistants, in-vehicle installs of Global Positioning System (GPS) receivers, and the upcoming deployment of mobile satellite digital audio has sprung a revitalized interest in faster, more affordable measurement techniques for antennas. This paper presents information on several new Spherical Near-field antenna measurement ranges developed by *ATDS-Howland*.

Keywords: antenna measurements, spherical near-field (SNF), low gain, omnidirectional antennas, scanners, indoor, outdoor, dielectrics, offset arm, phantom torso.

## 1. Background

The demand for wireless communications devices is revitalizing interest in advancing state-of-the-art for characterizing performance on a wide variety of antennas. Engineers are busy pioneering new methods to measure electromagnetic properties for an enormous quantity of trendy devices. Traditionally, antenna measurements have been made on outdoor or indoor test ranges possessing a relative large separation between source antenna and Device-Under-Test (DUT). Most of these ranges are referred to as *far-field* ranges where the measurements are often limited to principal plane patterns. As computing power and processor speeds increased, engineers began to employ less expensive techniques to compute (predict) the far-field radiation pattern from energy collected in the *near-field* (Fresnel) region of the radiating device. While techniques used to collect and process data are still evolving, *near-field* measurement ranges are becoming increasingly popular

with antenna manufacturers worldwide because a 3D representation of the radiation sphere can be generated.

The widespread deployment of wireless communications devices also increases the problems associated with finding suitable outdoor test sites. A shielded indoor anechoic test site provides a practical method to isolate the measurement system from the operating world.

## 2. Market Watch

The rapid deployment of mobile digital communications technology and other wireless devices is generating a need for engineers to create more affordable measurement tools that operate at faster speeds and collect an increasing amount of data. Millions of low-gain, omnidirectional antennas are produced each year for laptop PCs, wireless printer connections, automobiles, personal digital assistants, garage door openers, etc. These antennas are being mounted on-board trucks and automobiles for tracking, interoffice and personal communications devices for both entertainment and business uses. Automakers are slated to install digital radios capable of receiving commercial broadcast signals via satellite this year. For a small monthly subscription fee, travelers will be listening to clear, fade-free, digital audio.

## 3. Quality & Cost

Due to enormous market demand for antennas, and due to the highly competitive nature of the wireless communications industry, wireless device and antenna manufacturers are becoming increasingly concerned over *quality and cost* of performance. Manufacturers are quoted as

spending more time on designing the electronic circuitry and software elements of the devices than on the radiating “antenna” aspects of the device. Consequently, their efforts are often wasted due to poor radiation performance of the antenna element. Poor performance results in signal dropouts and therefore, interrupted communications. Engineers, mostly with digital backgrounds, are now faced with employing techniques to measure the complex, analog “antenna” portion of their designs. Fortunately, for these engineers, technology is now available that provides a cost-effective method for solving these complex issues.

#### 4.0 Solutions

**ATDS-Howland** recently installed two different types of SNF ranges that employ techniques that are likely to become commonplace in the wireless test community.

The *drive-on outdoor* SNF range (see figure 1),



**Figure 1**

consists of an Azimuth (vehicle) Phi ( $\phi$ )-axis rotating positioner and dual gantry near-field probe Theta ( $\theta$ )-axis positioner. The Theta axis mast trusses are made from structural fiberglass to minimize reflections. The probe boom consists of helical-wound fiberglass pipe. Operating parameters are listed in Table 1.

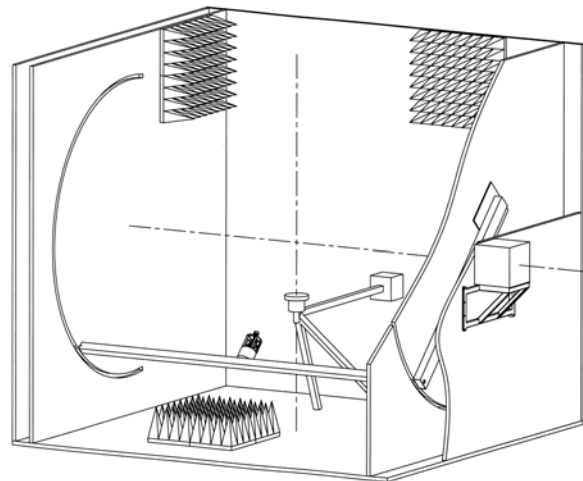
The outdoor SNF range’s probe assembly lowers below grade level to allow the same real estate to perform as a ground reflection range. This latter feature is becoming ever popular as companies strive to cut back real property costs. Rather than rotating the entire turntable’s surface, a cost-saving drive-on, grease-rack style vehicular guide is used. The grease-rack style mechanism

allows vehicular “self-centering” on the positioner’s Azimuth axis, thereby reducing costly set-up time.

Parameter	Specification
Frequency Range	100 MHz – 2 GHz
Probe Rotation Radius	27 feet (8.23m)
Boom Width	24 feet (7.31m)
Rotation Velocity	0.5 deg/sec max
Travel Limits	0-90 deg
Positioning Accuracy	+/- 0.1 deg
Wind Speed	40 mph (64.8 Km/h) max

**Table 1**

The *indoor test-in-a-box* concept (see figure 2), accommodates both SNF and far-field testing options. Developed for wireless antennas, the *test-in-a-box* offset arm scanner and Azimuth turntable (see figure 3), are made from dielectric materials to reduce range reflectivity levels that could induce measurement errors. The scanning mechanism allows collection of a full sphere of data. Housed in a 60 dB shielded box, this *indoor-type* range occupies a minimal shopspace of about an 18ft (5.5m) cube. The nominal operating frequency range is 750 MHz to 6 GHz.

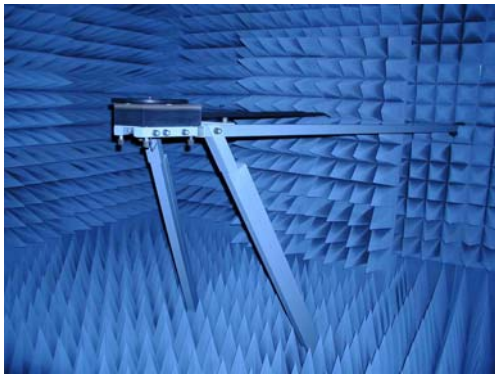


**Figure 2**

General specifications for the *test-in-a-box* are listed in Table 2.

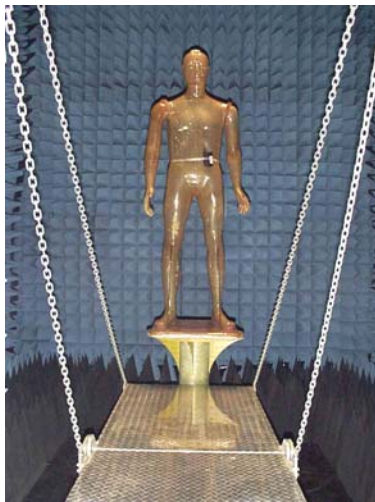
Parameter	Turntable ( $\phi$ )	Probe ( $\theta$ )
Travel	+/- 200 deg	200 deg
Speed	72 deg/sec	10 deg/sec
Accuracy	+/-0.05 deg	+/-0.05 deg
Resolution	0.01 deg	0.01 deg
Capacity	80 lb, 36.3 kg	30 lb, 13.6 kg
Probe Radial Position Error		0.05 inches with 10 lb., 4.5 kg probe
$\theta$ Cross-Arm Radius		72 in, 1.82m

**Table 2**

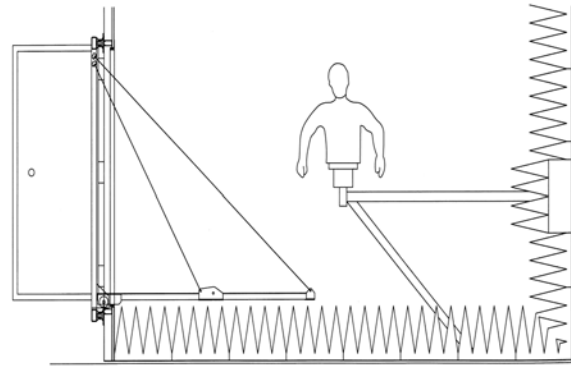


**Figure 3**

The *test-in-a-box* uses a swing-down cross-bridge platform (see figure 4), allowing convenient user access to the Azimuth turntable.



**Figure 4**



**Figure 5**

The turntable is supported by dielectric members, (see figure 5), which suspend it in space slightly below the vertical center of the test chamber. The turntable support members are attached to the chamber walls and floor in such a manner that the probe antenna can travel under the turntable. The vertical position of the turntable is set to place the DUT in the approximate center of the chamber when a phantom torso is used for testing. If the torso is not used, a dielectric pipe can be attached to the turntable to support the DUT, or the turntable platen can be removed and replaced with a custom platen configured for the desired test.

Both test solutions use modern Agilent instrumentation but may be configured to accommodate equipment from other vendors. Each system operates with the SNF software transformation algorithms developed by the National Institute of Standards and Technology (NIST).

## 5.0 Conclusions

Analytically complex techniques employing Spherical Near-field technology to assess electrical performance of radiating devices are now becoming more commonplace throughout the wireless industry. Two methods that simplify the measurement process are described herein. As communications systems continue to progress, advanced testing solutions are surely to evolve further. Ultimately, device manufacturers and consumers will be the top beneficiaries.